

# SNV50 Series Integral Bonnet Needle Valves

## Features

- Pressure rating up to 5000psig (344bar) at 21°C (70°F).
- Temperature rating from -54°C (-65°F) to 232°C (450°F) with standard PTFE packing and up to 315°C (600°F) with optional PEEK packing.
- Choice of material : Standard SS316 and available in Alloy 400 & Brass.
- Available Sour Gas service per NACE MR0175.
- Applications : General Purpose Gas, Water and Oil
- Variety stem tips include Vee, Regulating and Soft-Seat with PCTFE (KEL-F).
- Forged body with straight and angle patterns.
- Stem threads are hard chrome-plated for maximum service life.
- Packing nut enables easy external adjustments to ensure leak-free stem seal.
- Variety of end connections include reliable S-LOK tube fittings, male/female NPT & ISO threads.



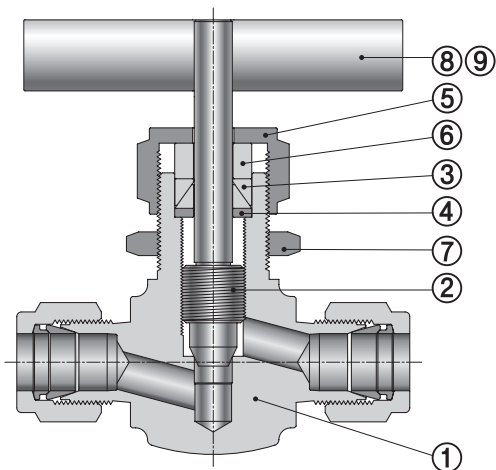

## Materials of Construction



No	Component	Material			
		Stainless Steel	Brass	Alloy 400	
1	Body	SS316/ A182	Brass / B124	Alloy 400 / B564	
2	Stem	Vee	Chrome Plate SS316 / A479 or A276	SS316 / A479 or A276	
		Soft Seat			Alloy R-405 / B164
		Regulating			
2a	Stem Tip	PCTFE (KEL-F)			
3	Packing	PTFE (Optional PEEK)			
4	Packing Ring	SS316 / A479 or A276	Brass / B16	Alloy R-405 / B164	
5	Packing Nut	SS316 / A276			
6	Gland				
7	Panel Nut				
8	Knob Handle	Black Phenolic Knob (Standard)			
	Bar Handle	SS316 / A276			
9	Set Screw	Stainless Steel			

## Technical Data

### Choice of Stem Tip's Available

Vee Stem	Regulating Stem	Soft Seat Stem
For pressure tightness even at elevated temperatures	For flow rate control	For repetitive shut-off
		

### Pressure-Temperature Rating with Packing and Body Material

Valve Material	Stem	PTFE Packing (Standard)		PEEK Packing (Optional)	
		Temperature Range °C (°F)	Pressure Rating @38°C(100°F)	Temperature Range °C (°F)	Pressure Rating @Max. Temp.
Stainless Steel 316	Vee & Regulating Stem (Metal Seat)	-54°C to 232°C (-65°F to 450°F)	5000psig (344 bar)	-54°C to 315°C (-65°F to 600°F)	3130psig (215 bar)
	Soft Stem (PCTFE Seat)	-54°C to 93°C (-65°F to 200°F)		-54°C to 93°C (-65°F to 200°F)	4295psig (295 bar)
Brass	Vee & Regulating Stem (Metal Seat)	-54°C to 204°C (-65°F to 400°F)	3000psig (206 bar)	-54°C to 204°C (-65°F to 400°F)	390psig (26 bar)
	Soft Stem (PCTFE Seat)	-54°C to 93°C (-65°F to 200°F)		-54°C to 93°C (-65°F to 200°F)	2350psig (161 bar)
Alloy 400	Vee & Regulating Stem (Metal Seat)	-54°C to 232°C (-65°F to 450°F)	3000psig (206 bar)	-54°C to 260°C (-65°F to 500°F)	2375psig (163 bar)
	Soft Stem (PCTFE Seat)	-54°C to 93°C (-65°F to 200°F)		-54°C to 93°C (-65°F to 200°F)	2460psig (181 bar)

### Temperature-Working Pressure

- The class rating and rated working pressure are the way that ASME standards simplify the design process.
- The pressure rating is governed by the allowable stress for each different material group, class rating and service temperature.

ASME Material Group	Table 2-2.2	N/A	Table 2-3.4
ASME Class Rating	2080	N/A	1500
Material Name	Stainless Steel 316	Brass	Alloy 400
Temperature, °C (°F)	Working Pressure, psig (bar)		
-54°C (-65°F) to 38°C (100°F)	5000 (344)	3000 (206)	3000 (206)
93°C (200°F)	4295 (295)	2350 (161)	2630 (181)
148°C (300°F)	3875 (266)	2050 (141)	2450 (168)
204°C (400°F)	3560 (245)	390 (26)	2365 (163)
260°C (500°F)	3310 (228)	-	2365 (163)
315°C (600°F)	3130 (215)	-	-

- Pressure ratings of valves with S-LOK end connections are determined by the tubing material and wall thickness.
- Pressure rating of valve is sometimes limited to the working pressure of pipe ends and the tubing connected.

### Flow Coefficient (Cv) with Number of Handle Turns

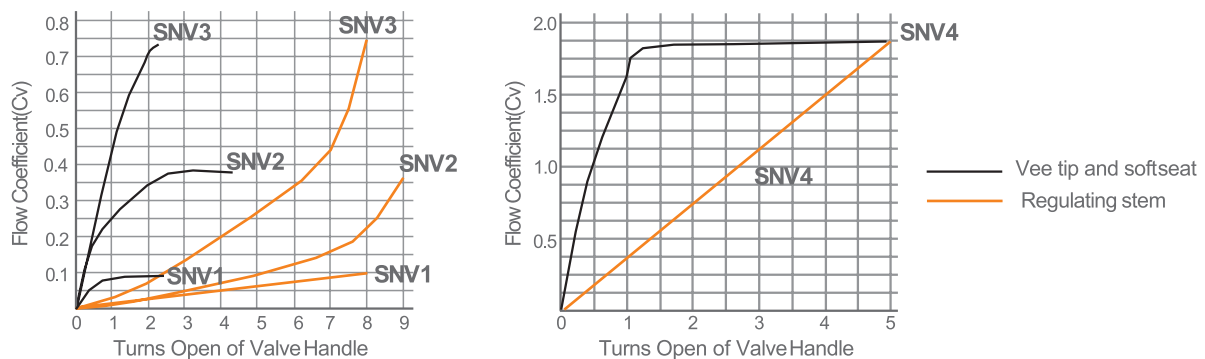

### Testing

- Every valve is factory tested with Nitrogen @ 1000psig (69bar)
- Seats have a maximum allowable leak of 0.1 (SSCM).
- Hydrostatic shell tests is performed optional with water at 1.5 times the working pressure.

## Ordering Information & Dimensions

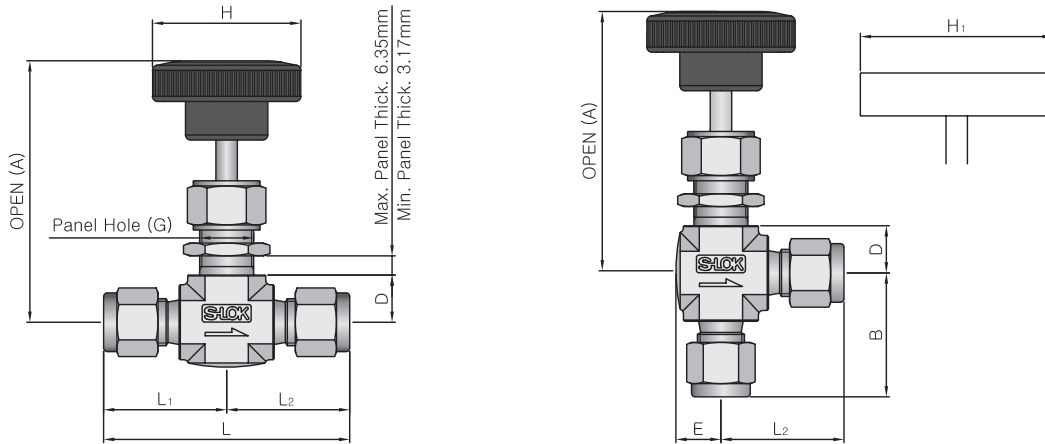

Ordering Number	Orifice (mm)	Cv	End Connections		Dimensions (mm)										
			Inlet	Outlet	A	B	L	L <sub>1</sub>	L <sub>2</sub>	E	D	H	H <sub>1</sub>	G	
SNV1	F-2N	2.0	0.09	1/8" Female NPT		61.0	21.0	42.0	21.0		9.5	11.0	35.0	32.0	13.5
	M-2N			1/8" Male NPT											
	MS-2N2T			1/8" Male NPT	1/8" S-LOK										
	S-2T			1/8" S-LOK											
	S-3M			3mm S-LOK											
SNV2	F-2N	4.4	0.37	1/8" Female NPT		61.0	21.0	42.0	21.0		9.5	11.0	35.0	45.0	13.5
	M-2N			1/8" Male NPT											
	M-4N			1/4" Male NPT											
	MS-4N4T			1/4" Male NPT	1/4" S-LOK										
	S-6M			6mm S-LOK											
	S-4T			1/4" S-LOK											
	S-8M			8mm S-LOK											
SNV3	F-4N	6.4	0.73	1/4" Female NPT		77.0	28.0	56.0	28.0		13.0	13.5	47.0	64.0	19.8
	F-4R			1/4" Female ISO Thread											
	MF-4N			1/4" Male NPT	1/4" Female NPT										
	MS-4N6T			1/4" S-LOK	3/8" S-LOK										
	M-6N			3/8" Male NPT											
	MS-6N6T			3/8" Male NPT	3/8" S-LOK										
	MS-6N8T			3/8" Male NPT	1/2" S-LOK										
	S-10M			10mm S-LOK											
	S-6T			3/8" S-LOK											
	S-12M			12mm S-LOK											
	S-8T			1/2" S-LOK											
SNV4	F-6N	9.5	1.80	3/8" Female NPT		92.0	38.0	76.0	38.0		19.0	19.0	63.0	76.0	26.0
	F-6R			3/8" Female PT											
	F-8N			1/2" Female NPT											
	F-8R			1/2" Female ISO Thread											
	M-8N			1/2" Male NPT											
	MF-8N			1/2" Male NPT	1/2" Female NPT										
	S-8T			1/2" S-LOK											
	S-12T			3/4" S-LOK											

\* Dimensions are for reference only and are subject to change.

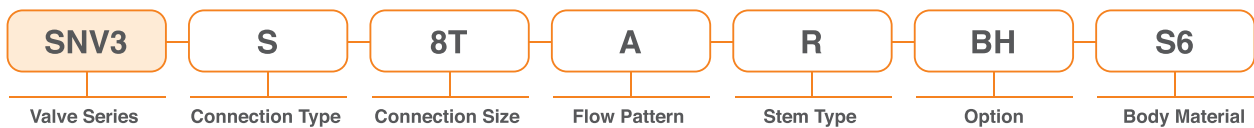

- Nil : Straight
- A : Angle Pattern
- Nil : Vee Stem
- R : Regulating Stem
- K : Soft Seat Stem
- Nil : Standard
- BH : Bar Handle
- PK : PEEK Packing
- SG : Sour Gas Service
- S6 : 316 Stainless Steel
- BS : Brass
- A400 : Alloy 400